



Institutional Animal Care Program (IACP)	
Title: Isoflurane Waste Anesthetic Gas Policy	
Policy number IACP 020	Date in Effect: 05/13/11
Revision 4, 12/09/22	Revision Date: 03/13/26
In Effect <input checked="" type="checkbox"/> Rescinded <input type="checkbox"/>	Date Rescinded:

A) APPLICATION

Isoflurane is generally considered the anesthetic of choice for many procedures in animal research facilities. This agent is delivered using either a precision vaporizer or the open- drop method, a technique often used for rodents in research. Personnel using either method for delivering isoflurane may be exposed to waste anesthetic gases (WAG).

Although some studies report no adverse health effects from long-term exposure to low concentrations of waste anesthetic gases, several studies have linked such exposure to miscarriages, genetic damage, and cancer among operating-room workers. Studies have also reported miscarriages in the spouses of exposed workers and birth defects in their offspring. Therefore, NIOSH (National Institute for Occupational Safety and Health) is concerned about worker exposures to these gases and recommends controls to prevent exposures.

This policy is intended to provide isoflurane users with some basic guidelines for the proper use of isoflurane machines; describe its basic parts; describe what is needed to perform an open-drop technique; and provide explanation of the most common practices that will lead to human exposure.

B) RESPONSIBILITIES

- 1) It is the responsibility of Principal Investigators and their laboratory personnel who utilize gas anesthesia (e.g., isoflurane) in laboratory animals at UT San Antonio (UTSA) to abide by this policy.

C) REFERENCES

- 1) Taylor KT, Mook DM (2009). Isoflurane Waste Anesthetic Gas



~~Concentration Associated with the Open-Drop Method. *Journal of the American Association for Laboratory Animal Science*, **48(1)**, 61–64.~~

- 1) Moore ES, et al (2019). Influence of the Position of Charcoal Air-Filtration



~~Canisters on the Efficacy of Waste Isoflurane Scavenging as Assessed in a~~
Randomized Experiment. *Journal of the American Veterinary Association*,
254(12), 1459-1465.

- 2) [NIOSH Publication No. 2007- 151](#).
- 3) [International Chemical Safety](#) card for isoflurane.
- 4) [Safety Data Sheets effective 2012](#)

D) DEFINITIONS

- 1) NIOSH – National Institute for Occupational Safety and Health
- 2) WAG – Waste Anesthetic Gases = small amounts of volatile anesthetic gases that leak from the anesthetic breathing circuit or open-drop jar into the air of the procedure room during delivery of anesthesia. Animals may also exhale these gases during recovery from anesthesia.
- 3) ppm – parts per million.
- 4) SDS – Safety Data Sheets.
- 5) Passive scavenging – relies on the positive pressure from the anesthetic gas delivery system and/or the exhalation effort of the animal to drive contaminated exhaled air through a specially designed activated charcoal filter (e.g., F/Air, Enviro-Pure, etc.), which will adsorb and remove the waste anesthetic agent molecules before the air is discharged back into the room.
- 6) Active scavenging - involves using low-pressure high-flow ventilation to create a suction that captures contaminated air and safely discharges it from the room and the building. The simplest form of active scavenging is to actually deliver the anesthetic to the animal while it is placed within a properly functioning exhaust hood, downdraft table or under a snorkel. Other systems may also be appropriate.

E) ANESTHESIA DELIVERY EQUIPMENT

- 1) Isoflurane vaporizer – precision delivery system designed for “out of circuit” use in continuous flow techniques of inhalation anesthesia (*Figure 1*).



a) ~~Gas exposure risks.~~

- (1) Exposure to gas from improperly closed induction chamber.
- (2) Leaks from connections between various system components.
- (3) Improper fit of mask or nose cone on the animal.



~~(4) Not using a scavenging system.~~

- (5) Spilling liquid anesthetic agent while filling vaporizer reservoir.
- (6) Filling vaporizer outside of the fume hood or away from snorkel.
- (7) Working in room or area with poor ventilation.
- (8) Setting vaporizer concentration too high.
- (9) Turning on vaporizer before attaching breathing system to animal.
- (10) Allowing vaporizer to remain on after animal is disconnected from the anesthesia system.
- (11) Using activated charcoal canisters beyond their useful life by allowing them to exceed their weight limit or number of hours as stated on the canister label (*Figure 2*).
- (12) Length of scavenging tube from animal to passive or active scavenging system too great.

b) Practices to minimize or eliminate exposures.

- (1) Utilize scavenging system (passive or active). Active scavenging is generally superior to passive.
- (2) Work in an exhaust hood or under a snorkel.
- (3) Work in well-ventilated room (10-15 air changes per hour is best).
- (4) Check connections for leaks.
- (5) Ensure mask or nose cone fits snugly on animal.
- (6) Distance yourself from the source of WAG (e.g., mask, induction chamber, animal) as much as possible to minimize exposure.
- (7) Turn off vaporizer after use.
- (8) Ensure you are using proper isoflurane concentration.
- (9) When possible, fill vaporizer under an exhaust hood downdraft table (exhaust out) or under a snorkel in a well-ventilated area.
- (10) Flush induction chambers for 10 seconds with oxygen (with active/passive scavenging in place) without isoflurane to allow



~~removal of WAG.~~

(11)Recap isoflurane bottle immediately after filling vaporizer reservoir.



-
- (12) ~~Check and maintain vaporizer. This includes having the unit certified annually or per manufacturer recommendations. Consult the LARC for further information.~~
- (13) Review SDS for isoflurane.
- (14) Position activated charcoal canisters correctly.
- (a) All canisters should be used in the upright (vertical) position (*Figure 3*). Placing them horizontally (*Figure 4*) leads to leakage of unfiltered WAG into the room.
 - (b) When using bottom-vented canisters, ensure they are not placed directly on a flat surface. (*Figure 5*). Doing so disrupts flow. Instead, position them in way that allows free flow through the vents (*Figure 6*).
 - (c) The IACUC recommends purchasing canisters with holes on top (top-vented canisters) (*Figure 7*).
- (15) Disposal of activated charcoal canisters.
- (a) Do not use beyond their useful life. Follow manufacturer's recommendation on when to dispose the canister (typically when it exceeds certain hours or weight increase).
 - (b) Disposal should be done through a chemical waste request
(<https://utsa.bioraft.com/raft/hazwaste/pickup-requests>).
- 2) Open-drop (jar) method under an exhaust hood, downdraft table or snorkel. Examples of open-drop methods:
- a) Direct application of an isoflurane dilution onto an absorbent material within a jar. The animal is then placed on a grate located above the absorbent material (to avoid direct contact of the animal with the anesthetic) and the lid is closed (*Figure 8*). Alternatively, the anesthetic may be applied to the absorbent material enclosed in a



~~pathology cassette to avoid direct animal contact with the anesthetic~~

(*Figure 9*). Anesthesia gas fills the jar and the rodent is subsequently anesthetized.

- b) Direct application of an isoflurane dilution onto an absorbent material within a



~~syringe casing (*Figure 10*) or 50-ml centrifuge tube.~~

- 3) Exposure can occur if:
 - a) Not utilizing a scavenging system (e.g., an exhaust hood, downdraft table or under a snorkel).
 - b) Work area or room with poor ventilation.
 - c) Using incorrect concentration.
 - d) Spilling liquid anesthetic agent while filling.
 - e) When opening the induction chamber without prior flushing of the system.
- 4) Practices to minimize or eliminate exposure:
 - a) Flush the induction chamber just prior to opening the lid as follows:
 - (1) Turn anesthesia dial to 0% (*Figure 12*)
 - (2) Keep oxygen flow on ((*Figure 12 & 13*)
 - (3) Press the Flush Button for approximately 2-4 sec (*Figure 13*). This flushes isoflurane out of the chamber and replaces it with O₂.
 - (4) You can now open the chamber lid to remove the animal (*Figure 14*)
 - (5) Close the lid and turn the anesthesia dial back on if anesthesia is required for animals left in the chamber.
 - b) Only use open-drop method in an exhaust hood, downdraft table or under a snorkel.
 - c) Distance yourself from the source of WAG (e.g., mask, induction chamber, animal) as much as possible to minimize exposure.
 - d) Make sure the open drop jar lid is properly closed during induction and after use.
 - e) Use correct concentration.
 - f) Fill the open drop jar under chemical hood.
 - g) Work in a well-ventilated room.
 - h) Utilize an induction chamber designated for WAG scavenging (*Figure 11*).
 - i) Recap isoflurane bottle immediately after use.



~~j) Review SDS for isoflurane.~~

F) ENVIRONMENTAL AND WORK RISK ASSESSMENT

- 1) Personal monitoring can be conducted at the employee's breathing zone to determine WAG exposure for the employee. The monitoring is performed using a passive dosimeter, which collects gas on a media and is then analyzed by a laboratory. For more information contact <https://research.utsa.edu/compliance/lab-safety/>.

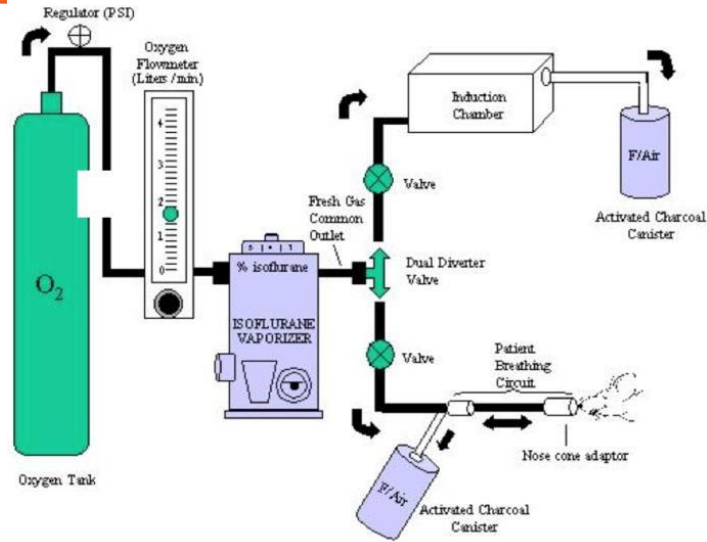

Figure 1



Figure 2



P *Figure 3*



Figure 4



Figure 5

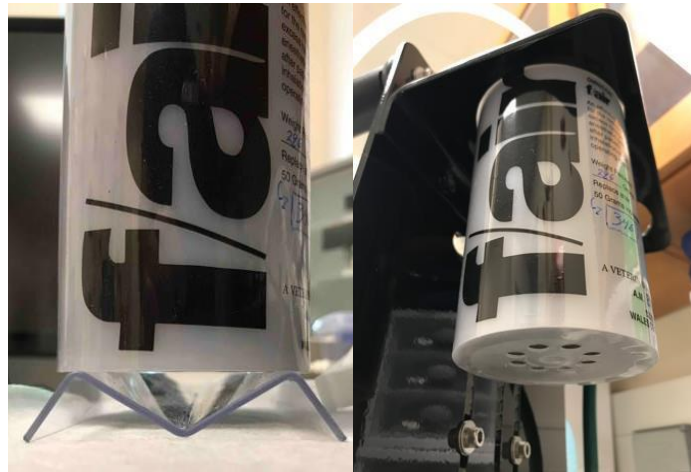

Figure 6



Figure 7 K

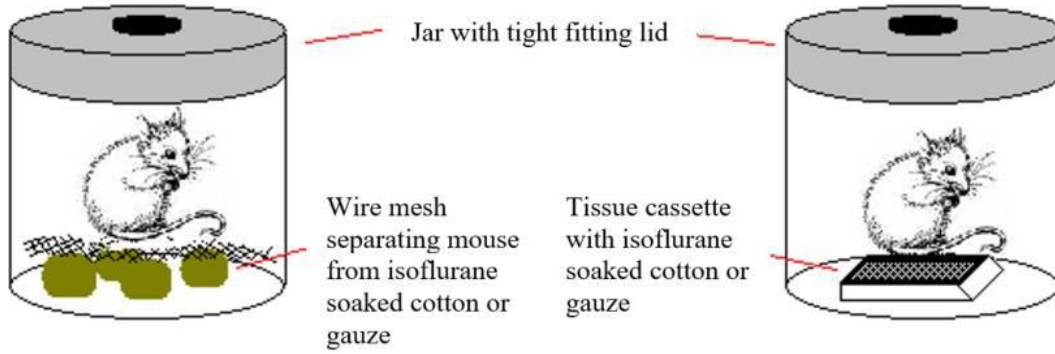

Figure 8

Figure 9

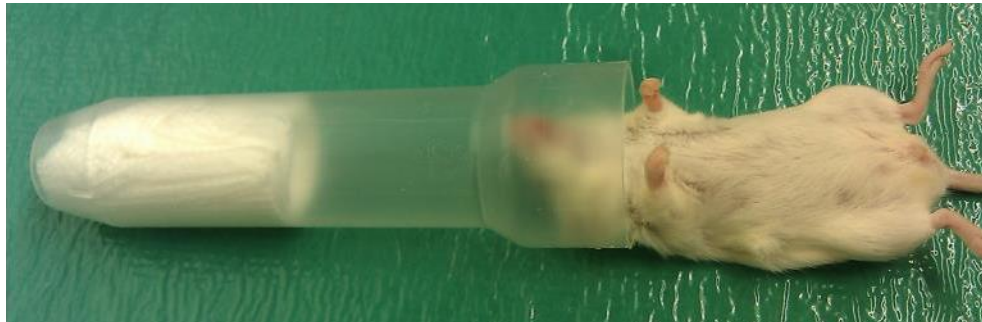

Figure 10



Figure 11

Flush Button

Keep O₂ on

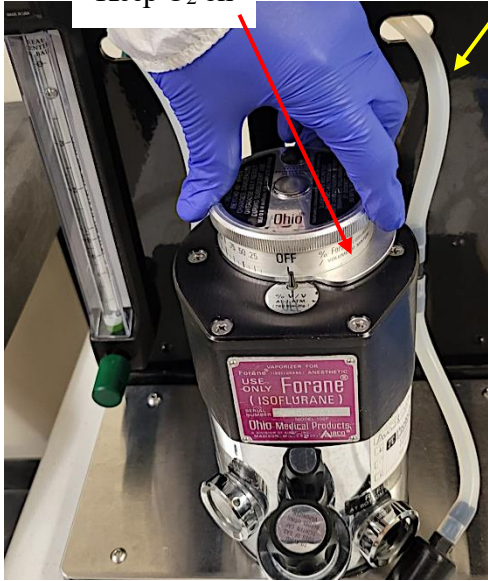

A)



Figure 13

may look different than depending on system



14